

MK NEWS

21-08

2021.08.17

JAPAN



Conveyor belt SUSHI

Written by : Yukie Koide



Japanese food is not just a boom for people for other countries people, it is becoming established as admirable food genre. Speaking of its representative, isn't it SUSHI that Japanese people are familiar with? Conveyor belt sushi, where you can enjoy delicious sushi by reasonable price, is an indispensable part of our daily lives. Conveyor belt sushi is a restaurant where you can pick up what you like from a rotating conveyor and eat it, but recently, the mainstream style is to order the sushi you want to eat on a panel and bring it to your table on a conveyor. You can enjoy not only for delicious food, find high technology system at Conveyor belt sushi.

A management system that attaches an IC chip to a sushi plate, figure out the best-selling items in real time, and uses it for demand forecasting. A mechanism that collects the length of run of each sushi, judges the freshness. After running specified length, it will be discarded automatically. Conveyor belt sushi is a restaurant that combines traditional Japanese foods and the latest technology.

 **YouTube**
[SUSHI CONVEYOR BELT RESTAURANT](#)

MK KASHIYAMA Stage. 2

MANUFACTURING

Stage 2. Factory produces brake pads. We are also manufacturing the material to use on brake pads. We are mixing many raw materials to make one brake pad material. There are strict regulation of materials in some countries.

Therefore, we are have to adapt it with our development manufacture division team. After that, development manufacture division team develop to materials that able to use at destination that has strict regulation and test it. After the sample has passed test, manufacturing division makes brake pad materials following that material recipe.

After brend material, we do it brake pad shape. The brake pad shape glued with backing plate that made in stage 1 factory, using by heat and pressure.

Next, brake pad cut by machine to make chamfer and slot for prevention squeal and crack of brake pad when people use. Our brake pad care about squeal, we are use fire to burning brake pad surface. It could help that easy to familiar with brake rotor, when people change to new brake pad. In addition, it becomes difficult to squeal.

Finally we pack brake pads with visual inspection, and we supply it to customer only production passed the test by quality assurance division team.



MK ITEM / INTERCHANGE NEWS

August New Item Information

■ BRAKE PAD

MK No.	Position	Application	Quotation Month
D11430MH Made in Indonesia FMSI No: D1848	Rear	Hyundai TUCSON (1600cc,1700cc,2000cc) 15.02- <EUR,USA,CAN,AUS,GEN,ME,IND> Kia SPORTAGE (1600cc,2000cc,2400cc) 15.08- <EUR,USA,CAN,AUS,GEN,ME>	August. 2021
D30016 Made in Indonesia	Front	Datsun MI-DO (1600cc) 14.12- <EUR> Datsun ON-DO (1600cc) 14.07- <EUR> Lada VAZ 2108,21083 <EUR,RUS> Lada 2190,GRANTA 12- <EUR,RUS>	August. 2021

August New Item Drawing Information

■ BRAKE PAD

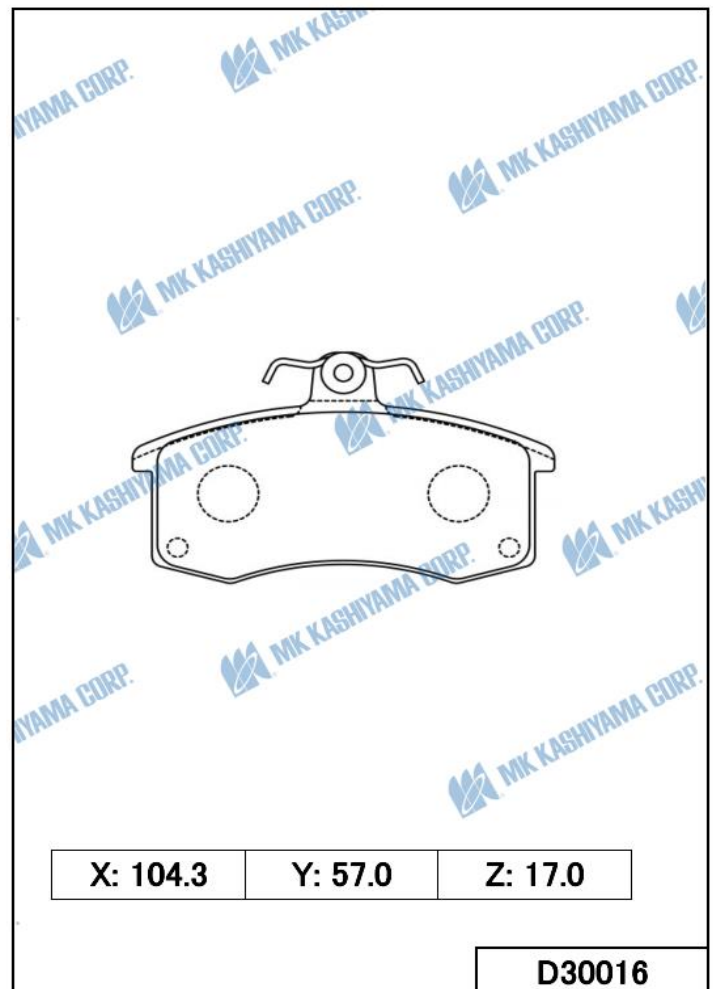
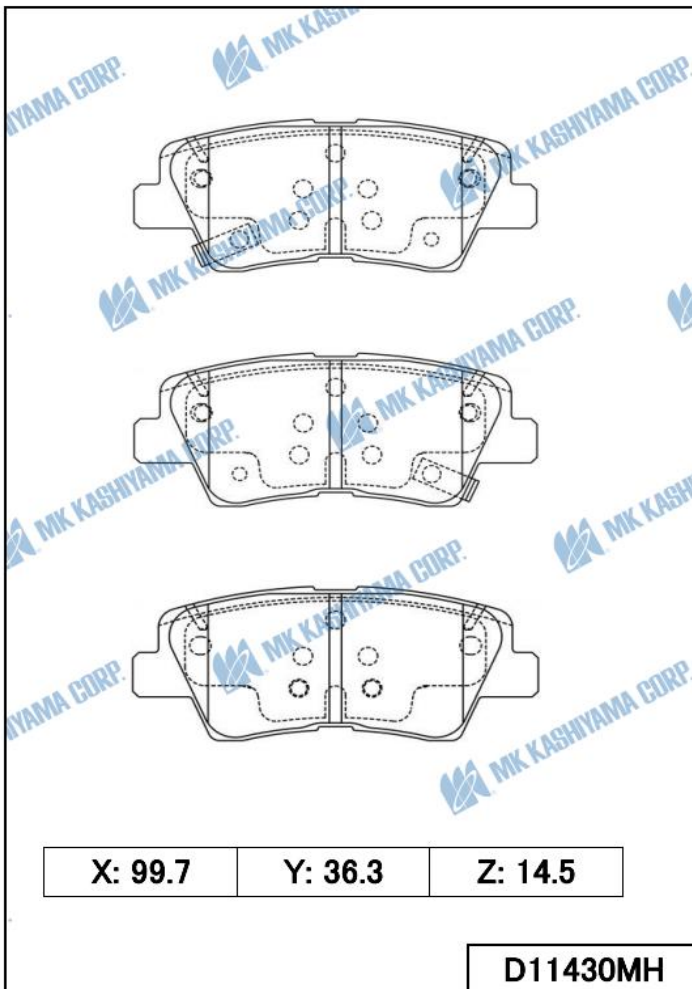

MK ITEM / INTERCHANGE NEWS

Valuable Information

■ Newly start Products with SHIM (Existing MK Item)

MK No.	Origin	Quotation Month
D2118MH	Made in Indonesia	August. 2021
D2252H	Made in Japan / Indonesia	August. 2021
D2254MH	Made in Indonesia	August. 2021
D2315H	Made in Japan / Indonesia	August. 2021
D2323MH	Made in Japan / Indonesia	August. 2021
D3163MH	Made in Indonesia	August. 2021
D3182MH	Made in Indonesia	August. 2021
D3188MH	Made in Japan	August. 2021

■ Newly start Product at Indonesia Factory (Existing MK Item)

*D6091

*D6113 are available in Indonesia from August order.

■ Interchange Information (Existing MK Item)

MK No.	Position	Application	Year
D1316MH	Front	NISSAN TIIDA C13Z (1600cc) CHINA MAKE <CHN>	2016.10-
D9027	Front	SUZUKI STINGRAY 1000cc PETROL <IND>	2013.09-
D11118MH	Rear	HYUNDAI SONATA (2000cc,2200cc) <ME>	2007.05-2007.09
D11302MH	Front	HYUNDAI GRANDEUR (3000cc) <KOR>	2010.12-2016.11
D11448MH	Front	HYUNDAI VELOSER N (2000cc) <USA,CAN,ME>	2018.09-
D11478MH	Rear	HYUNDAI PALISADE (2200cc,3500cc,3800cc) <GEN,ME,RUS,EUR>	2019.03-
K2386	Rear	SUZUKI SPLASH A5E312 <IDN>	-
K9968	Rear	SUZUKI GRAND EXCUDO XL7 JA625W <IDN>	-

■ Changed SETS/CTN Products (Existing MK Item)

Since starting or planning to start with SHIM products, inner box size will be bigger than before for fit with SHIM products. This is why sets/ctn of without SHIM products also changed.

Below products will be changed from AUGUST and SEPTEMBER Order (End of NOVEMBER & DECEMBER shipment).

<From End of November shipment>

MK No.	Previous	Present	Origin
D2183M	18 sets/ctn	15 sets/ctn	Made in Japan / Indonesia
D2283M	18 sets/ctn	15 sets/ctn	Made in Japan / Indonesia
D2118M	15 sets/ctn	12 sets/ctn	Made in Japan / Indonesia

<From End of December shipment>

MK No.	Previous	Present	Origin
D6113	10 sets/ctn	5 sets/ctn	Made in Japan / Indonesia