

MK NEWS

21-07

2021.07.12

JAPAN

Hello Kitty

Written by : Kyoko Osawa

Cited from :

<https://www.britannica.com/topic/Hello-Kitty>

PROFILE

FULL NAME : Kitty White
 JAPANESE NAME : ハローキティ(Harō Kiti)
 BIRTHDAY : November 1st
 PLACE of BIRTH : Suburbs of London, England
 HIGHT : Stack of 5 Apples
 WEIGHT : 3 Apples
 HOBBIES :
 Baking cookies, collecting cute things
 LIKES :
 Mama's homemade apple pie, English, music, art

Hello Kitty, cartoon character whose likeness adorns hundreds of products for children and adults throughout the world.

Created in 1974 by the Japanese merchandising company Sanrio and known internationally as Hello Kitty, Kitty White is a small, round-faced, cartoon catlike girl with black eyes, a yellow nose, no mouth, and a red bow perched on her left ear. According to the "biography" established by Sanrio, Hello Kitty was born in suburban London, Hello Kitty's primary-coloured, simple, and wholesome world appealed to young children.

This character is a staple of the kawaii segment of Japanese pop culture. The Hello Kitty trademark has spread globally; Although mainly aimed at the pre-adolescent female market, the Hello Kitty product range goes all the way from purses, stickers and pen sets to toasters, televisions, clothing, massagers, and computer equipment. It has a cult-like following among adults as well, especially in Asia, where Hello Kitty adorns cars, purses, jewelry and many other high-end consumer products. Her fame has led her to the creation of two officially licensed theme parks, Harmonyland and the indoor Sanrio Puroland.



MK KASHIYAMA Stage. 1 Factory

MANUFACTURING

Stage 1. Factory has made back plate of brake pad. MK KASHIYAMA has been pressed automotive parts since 1960. Therefore, it is continue to press parts of brake pad. Our company are almost in-house manufacturing automotive production.



MK KASHIYAMA Stage 1 factory has been main manufacturing Brake Shoe. In addition This factory has been produced back plate of using brake pad. We have 3 stage of workplace, and Stage 1 is the oldest building. It was built in 1946. We are process from make a brake shoe products to packing it, in this factory. People who are working in Stage. 1 makes a product 111,000 pieces every month. It has packed by quality inspection and visual inspection.



QUALITY MANAGEMENT

For quality inspection are taken by quality assurance division according to the standard. Every day they are checking product. For visual inspection are taken by packing person at the process of manufacturing, they are doing it all products when they pack a product.

MK ITEM / INTERCHANGE NEWS

July New Item Information

■ BRAKE PAD

| MK No. | Position | Application | Quotation Month |
|--|--------------|---|-----------------|
| D1365MH Made in Indonesia FMSI No: D1959 | Rear | Nissan SAFARI (Y61 TB48DE) 1997.08- <EUR,GEN,ME,AUS,GCC> | July. 2021 |
| D6170M Made in Japan | Front & Rear | Fuso CANTER (FBAV0,FEAV0,FEDS0) 2019.05- <JPN> | July. 2021 |
| D20040MH Made in Indonesia FMSI No: D1080 | Front | Jeep COMMANDER (3.7L V6,4.7L V8, 5.7L V8) 2006-2010 <USA> Jeep GRAND CHEROKEE (3.0L Diesel Turbo V6, 3.7L V6, 4.7L V8, 5.7L V8) 2005-2010 <USA> | July. 2021 |
| D20179MHP Made in Indonesia FMSI No: D2085 | Front | Ford EVEREST (2.2L Diesel Turbo, 3.2L Diesel Turbo) 2015- <VNM> | July. 2021 |
| D20182MHP Made in Indonesia FMSI No: D2080 | Rear | Ford EVEREST (2.2L Diesel Turbo, 3.2L Diesel Turbo) 2015- <VNM> | July. 2021 |
| D20226MH Made in Indonesia FMSI No: D1528 | Front | Ford TOURNEO TT9 (2200cc,2300cc,2400cc,3200cc FWD) 2006-2014 <EUR> Ford TRANSIT TT9 (2200cc,2300cc,2400cc,3200cc FWD) 2006-2014 <EUR> | July. 2021 |

※ "P" means that D20179MH and D20182MH with the Spring.

July New Item Drawing Information

■ BRAKE PAD

| | | |
|----------|---------|---------|
| X: 121.0 | Y: 36.0 | Z: 17.0 |
|----------|---------|---------|

D1365MH

| | | | |
|---|----------|---------|---------|
| ① | X: 144.3 | Y: 59.8 | Z: 19.5 |
| ② | X: 144.3 | Y: 58.2 | Z: 19.5 |

D6170M

| | | |
|----------|---------|---------|
| X: 176.1 | Y: 56.6 | Z: 18.0 |
|----------|---------|---------|

D20040MH

MK ITEM / INTERCHANGE NEWS

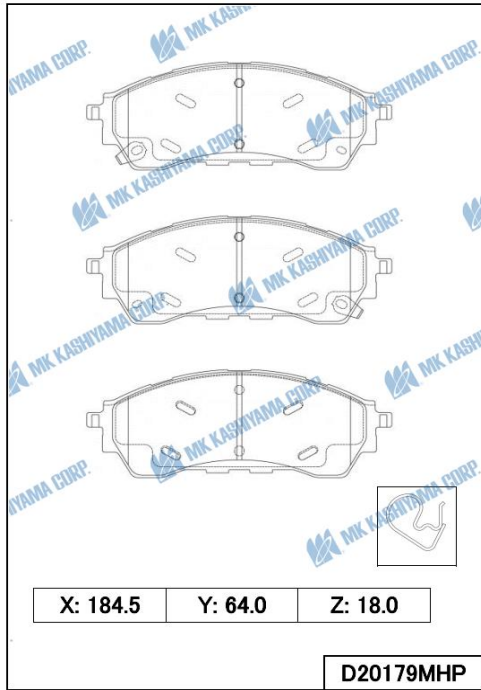

* With the Spring.

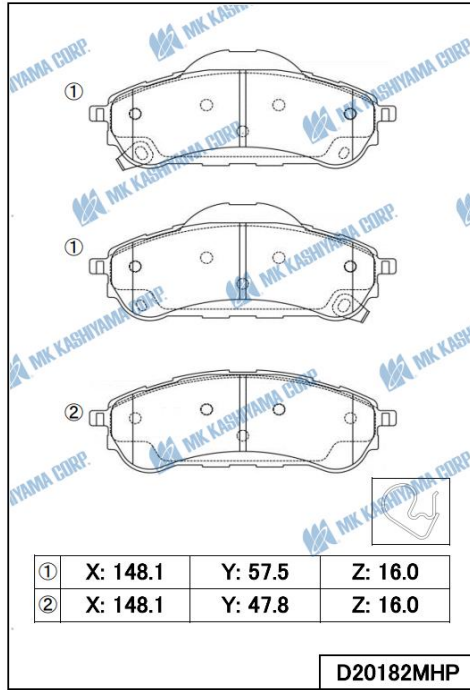

* With the Spring.

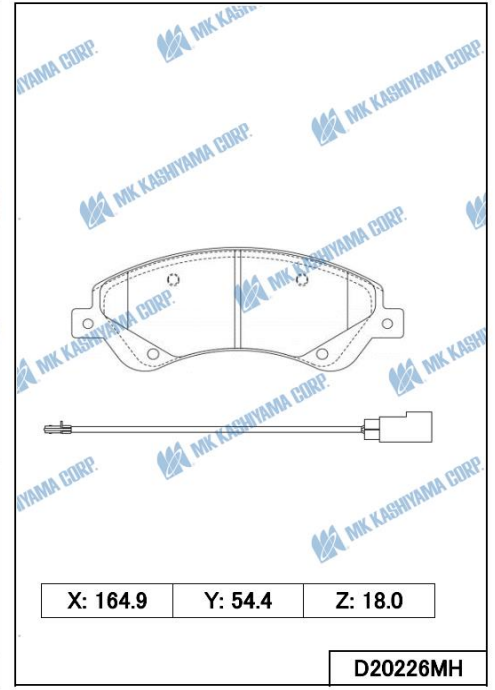

* ENCLOSED : Wear indicator (1 pce.)

Valuable Information

■ Newly start Products with SHIM (Existing MK Item)

| MK No. | Origin | Quotation Month |
|---------|---------------------------|-----------------|
| D4029MH | Made in Japan / Indonesia | July. 2021 |

■ Interchange Information (Existing MK Item)

| MK No. | Position | Application | Year |
|--------|----------|-------------------------------------|-----------------|
| D9027 | Front | SUZUKI STINGRAY 1000cc PETROL <IND> | 2013.09- |
| K9003 | Rear | SUZUKI ERTIGA AVI414 <IDN> | - |
| K9003 | Rear | SUZUKI SX4 1300cc,1600cc <IND> | 2006.03-2014.04 |

■ Changed SETS/CTN Products (Existing MK Item)

Since starting or planning to start with SHIM products, inner box size will be bigger than before for fit with SHIM products. This is why sets/ctn of without SHIM products also changed.

Below products will be changed from JULY Order (End of OCTOBER shipment).

<From End of October shipment>

| MK No. | Previous | Present | Origin |
|--------|-------------|-------------|---------------------------|
| D3182M | 15 sets/ctn | 12 sets/ctn | Made in Japan / Indonesia |